



CHAODA
Since 1984

PM
PATTONMYHRE
YOUR ENERGY PRODUCTS PARTNER



Pig Valve

With Patent Pending EZ Loader Technology
For a Safe and Efficient Pigging Operation

www.chaodausa.com | 832-939-9944 | 10633 W Airport Blvd, Ste 200 | Stafford, TX 77477

CHAODA PIG VALVE FOR MIDSTREAM

Since 1984, The Chaoda Group has been committed to producing high quality valves for the oil and gas market, at a competitive price. We are a fully integrated manufacturer owning all of the processes required to produce the very best valves. From the design to the foundry to the machining to the assembly and test, we own it and control it. This streamlined, tightly controlled system generates a highly consistent product that is tailored to your needs. Consistency in ownership has kept this strategy on track and maintained a philosophy of ongoing investment in Research and Development, as well as manufacturing efficiencies all aimed at staying ahead of the competition.

Through our commitment to quality, Chaoda maintains numerous industry certifications such as, ISO 9001, API 6D, API 600, API 607/6FA, API 624, API 641, CE/PED, API 591, and ISO 15848. The result is an ultimate blend of high-quality valves that you can afford.



TABLE OF CONTENTS

In this brochure we cover every aspect of the Chaoda Pig Valve from engineering specifications, special features, and operation.

Chaoda Pig Valve for Midstream	2
Table of Contents	2
Specifications & Standards	3
EZ-Loader Technology	4
Take a Look Inside	5
Chaoda Pig Valve Benefits	6
Design Features & PT Chart	7-8
Technical Seating Features	9
Engineering Dimensions	10
Launching & Receiving	11
Launching Operation	12
Receiving Operation	13
How to Order	14-15

SPECIFICATIONS

We are committed to product safety and quality.

We conform to the following standards:

API	AMERICAN PETROLEUM INSTITUTE
SPEC. 6D	Specification for Pipeline Valves
SPEC. 6FA	Fire Test for Valves
STD. 607	Fire Test for Quarter-turn Valves and Valves Equipped with Nonmetallic Seats
STD. 598	Valve Inspection and Testing
SPEC. Q1	Specification for Quality Programs for the Petroleum and Natural Gas Industry

ANSI / ASME	AMERICAN NATIONAL STANDARD INSTITUTE / AMERICAN SOCIETY OF MECHANICAL ENGINEERS
B1.20.1	Pipe threads, general purpose
B16.5	Pipe flanges & flange fittings
B16.10	Face-to-Face & End-to-End dimensions of Valves
B16.34	Valves - Flanged, Threaded, and Welding End
B31.3	Process Piping

NACE	NATIONAL ASSOCIATION OF CORROSION ENGINEERS
MR0175	Materials for use in H2S containing environments in oil & gas production

CSA	CANADIAN STANDARDS ASSOCIATION
Z245.12	Steel Flanges
Z245.15	Steel Valves
Z662	Oil and Gas Pipeline Systems

CRN	CANADIAN REGISTRATION NUMBERS
OC19355.2	Pig Valves

STANDARD MATERIALS

Size: 3"-20"

Pressure Class: ANSI 150 through ANSI 1500

Body: A350-LF2

EZ Loader Closure: A350-LF2

Ball: A350-LF2+3mil ENP

Seat Ring: A350-LF2+3mil ENP

Seat Insert: Devlon V

Seals: Low Temp Viton

Seat Springs: Inconel X-750

NOTE: Valves 6" and smaller come standard with A812-F316 Ball, Stem, and Seat Ring

Complete with API 6D Monogram

Standard temperature rating of -50F - 348F

additional materials available upon request

Pressure gauge included with every valve

PIG VALVE

EZ Loader Technology

A completely revolutionary valve with patent pending technology that improves the accessibility to the central components for easy maintenance and repair. Our pig valve comes with several customization options to fit your needs. No scaffolding required, as the hatch provides quick access to the torso for no hassle loading without the worry of crushed fingers. This system requires full cavity pressure relief before the latch can be freed while avoiding traditional threaded cap technology that can get balky and rusted under field conditions.

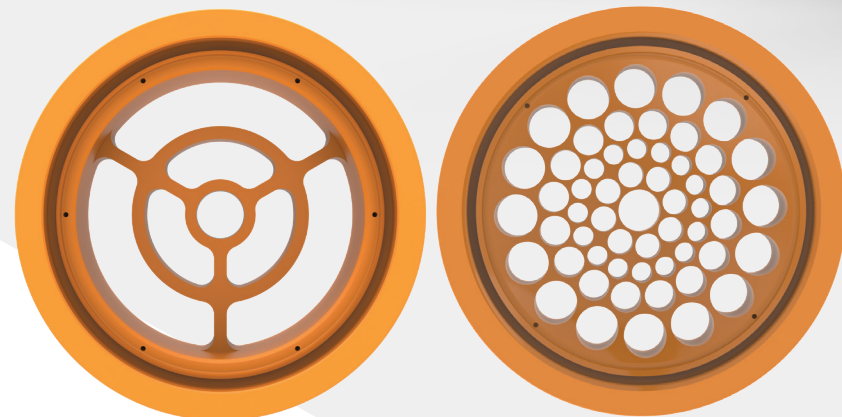

Liquid Service Catcher Plate (Standard)

Gas Service Catcher Plate (Available Upon Request)

Heavy duty Catcher Plates are constructed for longevity. The ability to vary the flow pattern through the Plate allows for optimal performance in a variety of services including liquids and solids containing streams.

Reversible Catcher Plate allows for retrofitting of the valves from a Receiver to a launcher or vice versa. Multiple seating options - including metal seated - as well as Catcher Plate flow patterns allow for the greatest flexibility in application specific designs available in the industry.

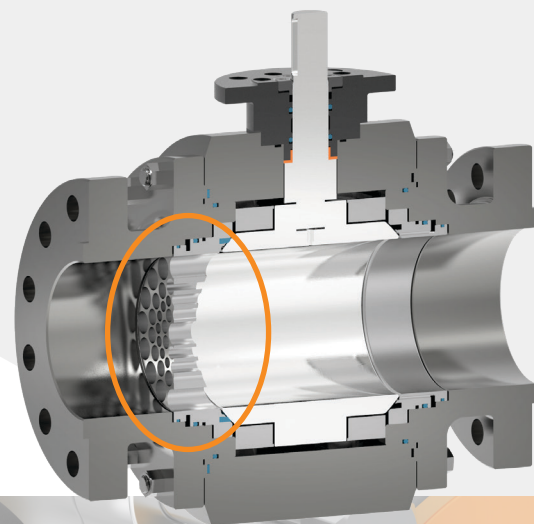

The Patent Pending **EZ Loader** system utilizes a side entry system of safety latches for ease of entry in the safest possible manner.

TAKE A LOOK INSIDE

- 1. Forged Body** - Provides superior structural integrity.
- 2. Ball** - Maximized sealing surface for reliable isolation.
- 3. Catcher Plate** - Prevents overtravel of Pig and contains it in the bore of Ball

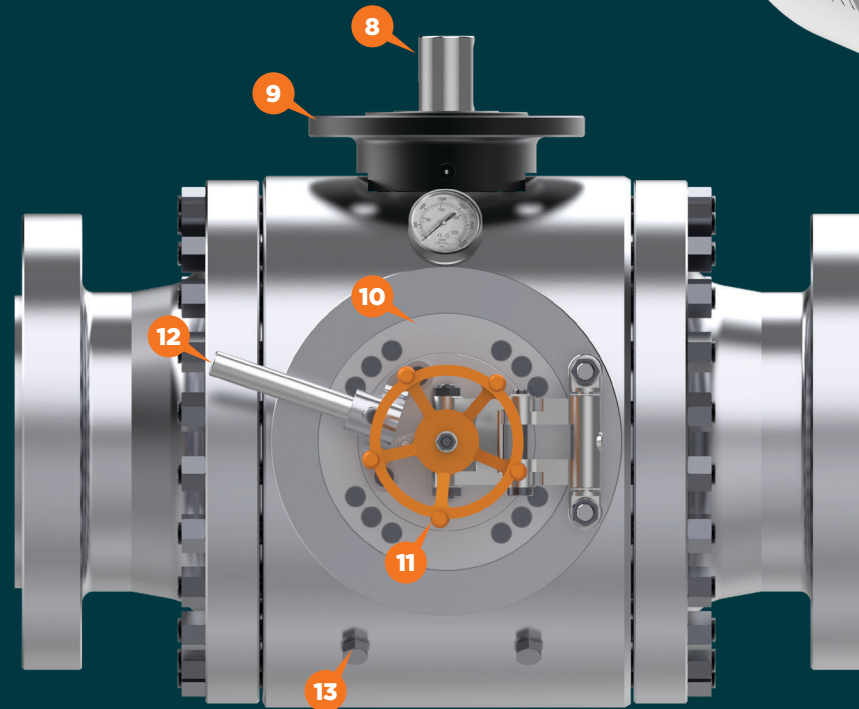
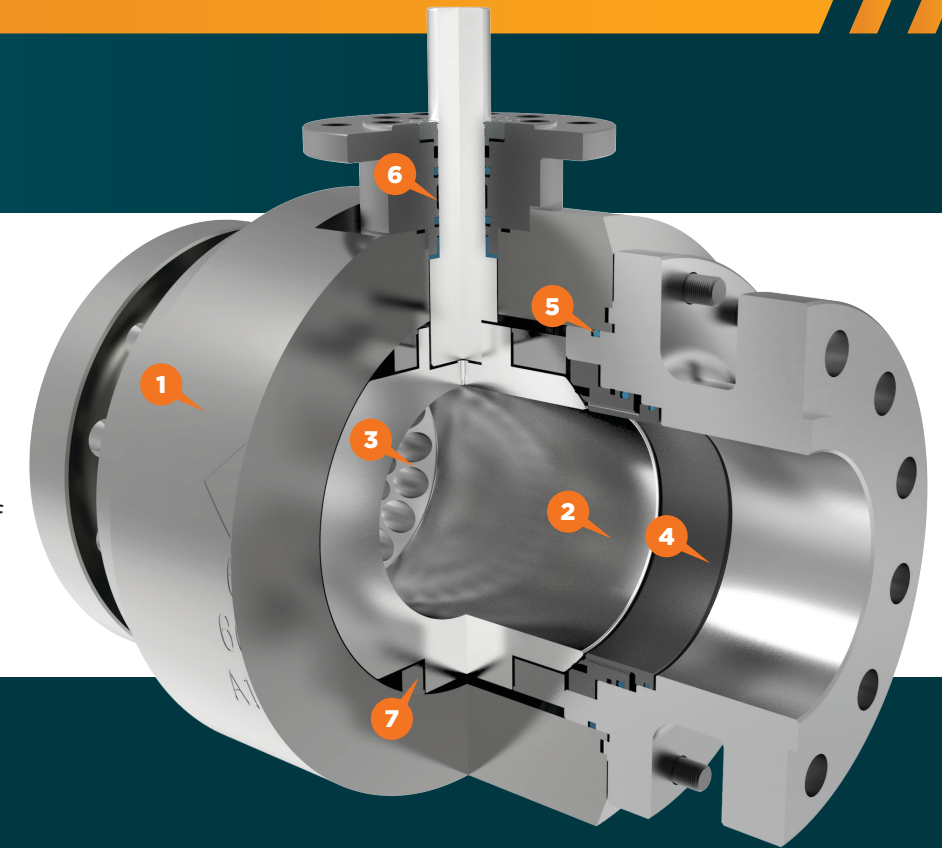

4. Seat - Designed for repeated zero-leakage shutoff.

5. Body Seal - Prevents leakage to atmosphere. Variety of materials available to suit application.

6. Stem Seal - Protects against leakage to atmosphere.

7. Trunnion Bearing - Helps ensure consistent operating torque.

8. Stem - High strength for maximum safety.

9. ISO Mounting Bracket - Standardizes Gear and Actuator mounting.

10. EZ Loader Closure - Patent pending loading system allowing side access and ultimate in safety.

11. Safety Valve - Prevents opening of Closure without proper cavity and Ball bore pressure relief.

12. EZ Loader Handle - Allows release of EZ Loader lock once cavity pressure is relieved allowing access.

13. Ball Bore and Cavity Relief - Allows pressure contained in ball bore to be relieved in order for closure to be opened. Each valve comes standard with four auxiliary ports for relief. Two vent valves and two drain plugs.

CHAODA PIG VALVE BENEFITS

Versus a Barrel Style Pigging System

- Smaller foot print with less piping and valving required for pigging facilities.
- Pigging valve may be used as a traditional block valve reducing the number of valves.
- Field construction time is reduced considerably due to the simple configuration and limited requirements for ground support, piers, pilings in a traditional configuration.
- Emissions are reduced in excess of 80% compared to fabricated barrel style launching and receiving traps.
- Built in safety features ensuring lower personnel risk through pigging operations.
- The application of pigging valves simplifies the pigging operation through a single quarter-turn valve concept that minimizes training and operations time while reducing maintenance and overall costs.

Chaoda Pigging Valve



Barrel Style Pigging System



CHOADA PIGGING VALVE	TRADITIONAL PIGGING VALVE
CLOSURE DESIGN	
EZ LOADER Closure	Threaded Closure
Closure Support Included	Davit Support Required
Contained O-Ring Seal	Loose O-Ring Seal
Front Facing Handwheel	Front Facing Handwheel
Front Entry Pig Opening	Top Entry Pig Opening
No Separate Wrench Required	Wrench Required
Locked Closed	Not Locked Closed
CATCHER/LAUNCHER PLATE	
Heavy Duty Integral with Seat Seal	Separate Seat Ring
Gas Catcher Plate	Gas Catcher Plate
Liquids Catcher Plate	Not Available
Plate Reversible With EZ Disassembly	Reversible

BENEFITS & DESIGN FEATURES

Our Pig Valves come with several features that allow for easier operation and maintenance.

- > **EZ Loader Closure**
Our EZ Loader Technology Simplifies the Pigging Process
 No threads removing possible pinch points, cross threading, and thread corrosion. No separate wrench required to open closure.
- > **Double Hinge Design**
 No davit support required. Closure is always in contact with the body. Adjustment nut included to improve closure alignment if required.
- > **Contained O-ring in Closure**
 No possibility of losing closure o-ring resulting in additional cost and time.
- > **Auxiliary Ports**
 Each valve comes standard with 5 auxiliary ports for bleeding, venting, and pressure gauge needs. These ports are supplied with two vent valves, two drain plugs, and one pressure gauge.
- > **Quick Bleed Safety Valve**
 Ensures any residual pressure is bled off before door can be opened. Enhancing the overall safety of the pigging operation.
- > **Front Entry PIG Opening**
 More convenient access. No need to lift PIG to the top of valve. Changes a 2-3-person job to a 1-2-person job due to the ease of operation.
- > **Mechanically Locked Closed**
 Cannot physically open closure door unless quick bleed safety valve has been fully vented.
- > **Integral Catcher Plate**
 Catcher plate is integral to the seat ring. Fewer internal parts to foul and allows for simple reversal of orientation.
- > **Liquids Catcher Plate**
 Allows for more media to pass through catcher plate, helping to eliminate paraffin issues. Significant cost savings over traditional barrel style launching and receiving traps.
- > **Reduced Emissions**
 Only have to vent gas from cavity of valve, thus, reducing emissions substantially over traditional barrel type systems.
- > **Production Optimization**
 Though the removal of liquids and debris that cause operational challenges and gathering systems inefficiencies.
- > **Corrosion Mitigation**
 Is enhanced through the effective removal of liquids and debris by frequent pigging operation through the safe operator friendly Chaoda Pigging Valve.

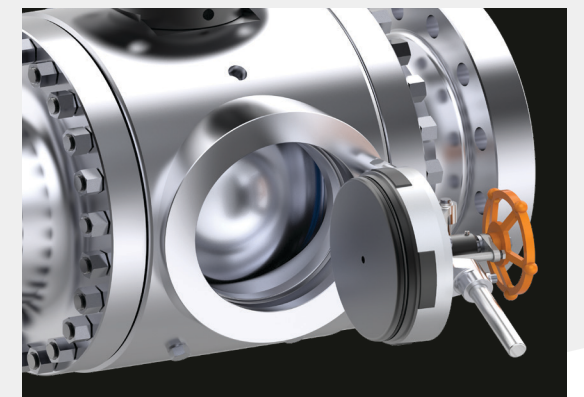
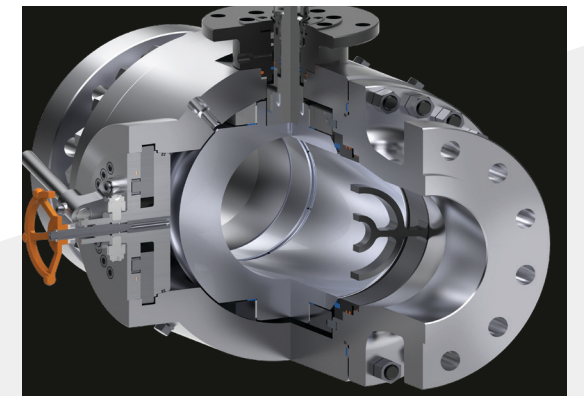
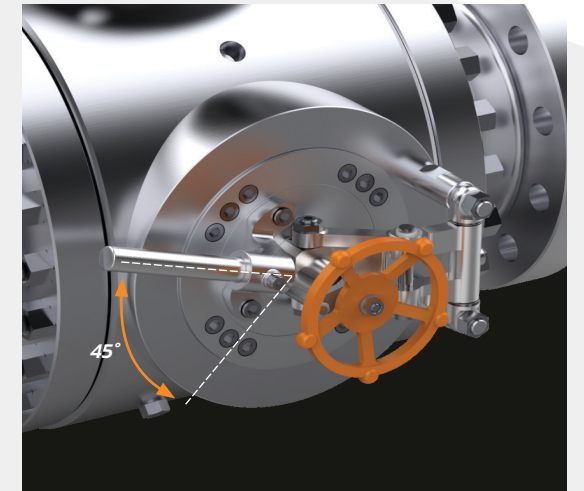

DESIGN FEATURES

Our Pig Valves come with several features that allow for easier operation and maintenance.

> Firesafe Standard Double Seal

2" - 20", Class 150 - 1500

- a) Weather seal
- b) Stem seal - braided carbon rope
- c) Primary stem seal

> Antistatic Device*

A stainless steel grounding plunger between the body/stem and stem/ball permits electrical continuity.

*2"-4" bore antistatic accomplished through trunnion bearing.

> Lubricant/Emergency Seat Seal

Special sealants may be injected into fittings that are located on the adapter flanges to restore sealing integrity if seat sealing surface is damaged.

> Emergency Sealant Injection System

The sealant injection system located on the body can be utilized in case of emergencies, o-ring damage, or if stem leakage occurs. A secondary check valve is installed under the sealant injection fitting to ensure the safety.

> Double Sealed Envelope Connections

A combination of an o-ring and firesafe gasket ensures a positive seal.

> Body/Adapter Seal Connection

An o-ring on this connection insures a positive seal.

> Heavy Duty Bearings

Heavy duty bearings balance the pressure load on the ball by reducing friction between ball and seat resulting in smooth and easy operation of valve.

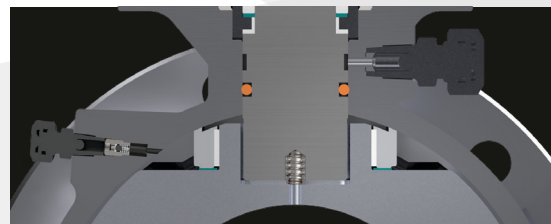
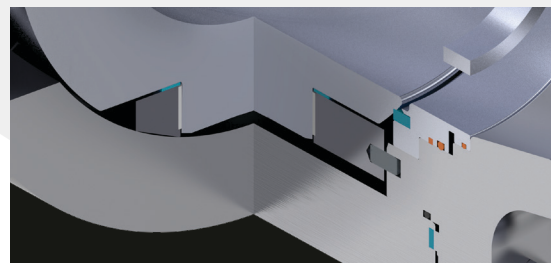
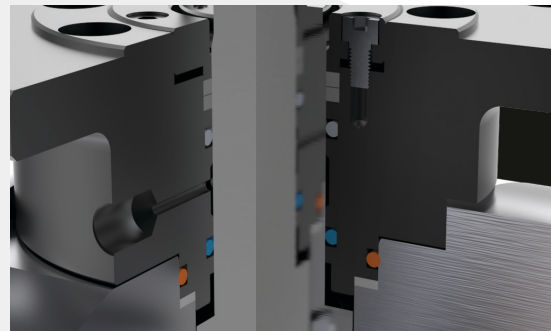

TECHNICAL SEATING FEATURES

There are a couple of built-in features for draining and pressure relief.

Double Block and Bleed

The double block and bleed condition is available in all seat design configurations. When the ball is in the closed position the body cavity pressure may be drained down to 'zero' by opening the bleed valve and draining the fluid by removing the drain plug. Each seat works independently assuring tight shut off seal against ball on the upstream and downstream side.

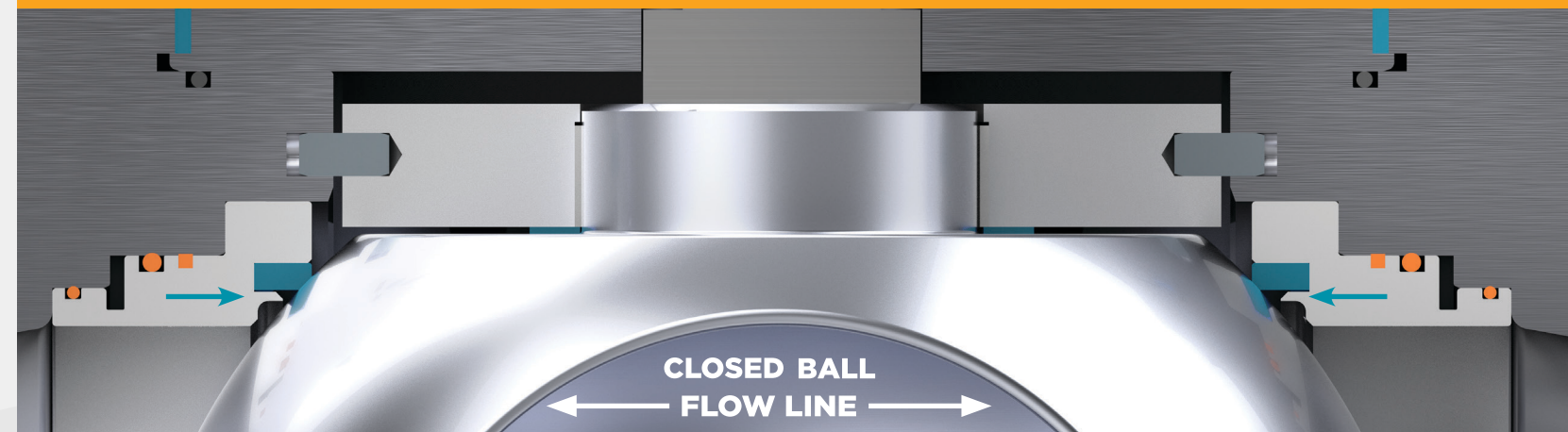

Self Relieving Seat Design

Upstream Seat

The difference in the area is multiplied by the line pressure which forces the seat against the ball surface. Also the springs behind the seat adds the force to the seat which keeps the seat in contact with the ball surface which provides the tight seal.

Downstream Seat

When the body cavity pressure exceeds the spring pressure, automatic pressure relief will occur by relieving the body cavity pressure past the downstream seat. This eliminates the need for the body relief valve.



PRESSURE & TEMPERATURE RATINGS FOR CHAODA PIGGING VALVE

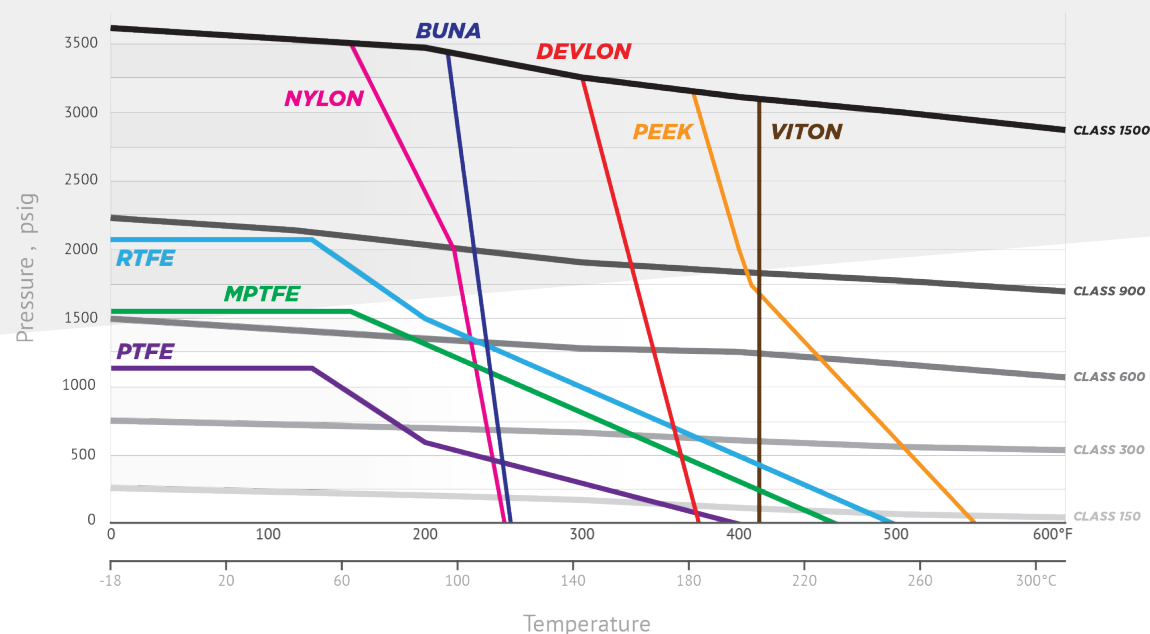

ENGINEERING SPECIFICATIONS

Measurements for available sizes and classes.

CLASS 150	OVERALL LENGTH* (A)				VALVE BORE (ØDN)
	RF		RTJ		
SIZE	IN	MM	IN	MM	IN (MM)
3"	12.75	324	13.12	333	3.56 (90)
4"	15.5	394	16	406	4.56 (116)
6"	18	457	18.38	467	6.75 (172)
8"	Consult with Chaoda for ANSI data				
10"	35.36	898	35.86	991	9.92 (252)
12"	40.75	1035	41.25	1048	11.93 (303)
16"	Consult with Chaoda for ANSI data				

CLASS 300	OVERALL LENGTH* (A)				VALVE BORE (ØDN)
	RF		RTJ		
SIZE	IN	MM	IN	MM	IN (MM)
3"	14	356	14.12	359	3.56 (90)
4"	16	406	16.5	419	4.56 (116)
6"	18.88	480	19.38	492	6.75 (172)
8"	28.5	724	29	737	8 (203)
10"	35.36	898	35.86	991	9.92 (252)
12"	40.75	1035	41.25	1048	11.93 (303)
16"	54	1372	54.5	1384	15.25 (387)

Chaoda Pigging Valve 4" and Below

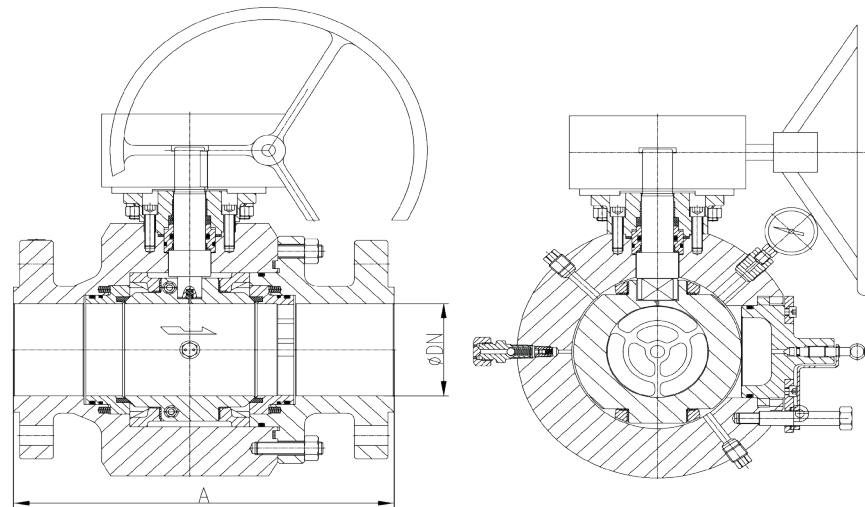

CLASS 600	OVERALL LENGTH (A)				VALVE BORE (ØDN)
	RF		RTJ		
SIZE	IN	MM	IN	MM	IN (MM)
3"	14	356	14.12	359	3.56 (90)
4"	17	432	17.12	435	4.56 (116)
6"	22	559	22.12	562	6.75 (172)
8"	31.2	792	31.32	796	8 (203)
10"	37.12	943	37.25	946	9.92 (252)
12"	42.06	1068	42.19	1071	11.93 (303)
16"	54	1372	54.12	1375	15.25 (387)

Chaoda Pigging Valve 6" and Above

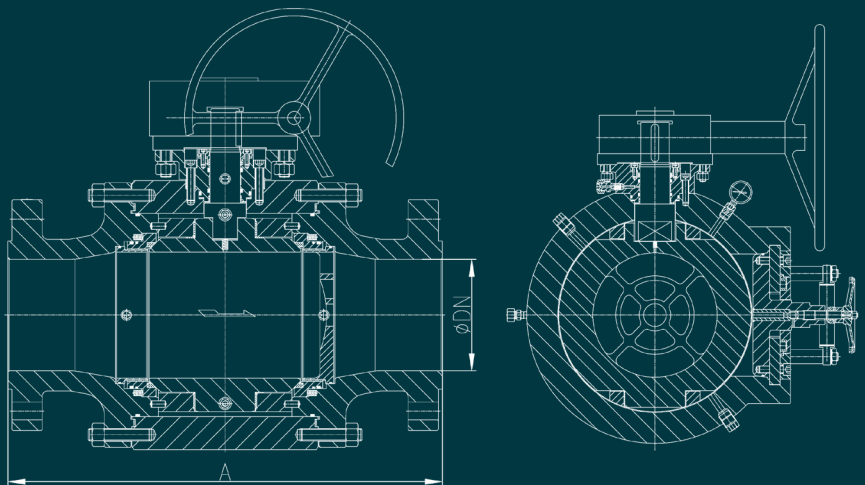

CLASS 900	OVERALL LENGTH (A)				VALVE BORE (ØDN)
	RF		RTJ		
SIZE	IN	MM	IN	MM	IN
3"	15	381	15.12	384	3.56 (90)
4"	18	457	18.12	460	4.56 (116)
6"	29	737	29.12	740	6.62 (168)
8"	35	889	35.12	892	8 (203)
10"	Consult with Chaoda for ANSI data				
12"	47	1194	47.12	1197	11.93 (303)
16"	Consult with Chaoda for ANSI data				

*Face to Face Length does not meet API Spec. '6D', ASME 'B16.10', or CSA Z245.15.

Note: Design specifications subject to change without prior notice.

LAUNCHING & RECEIVING

The Catcher Plate, Launcher, and Receiver Options

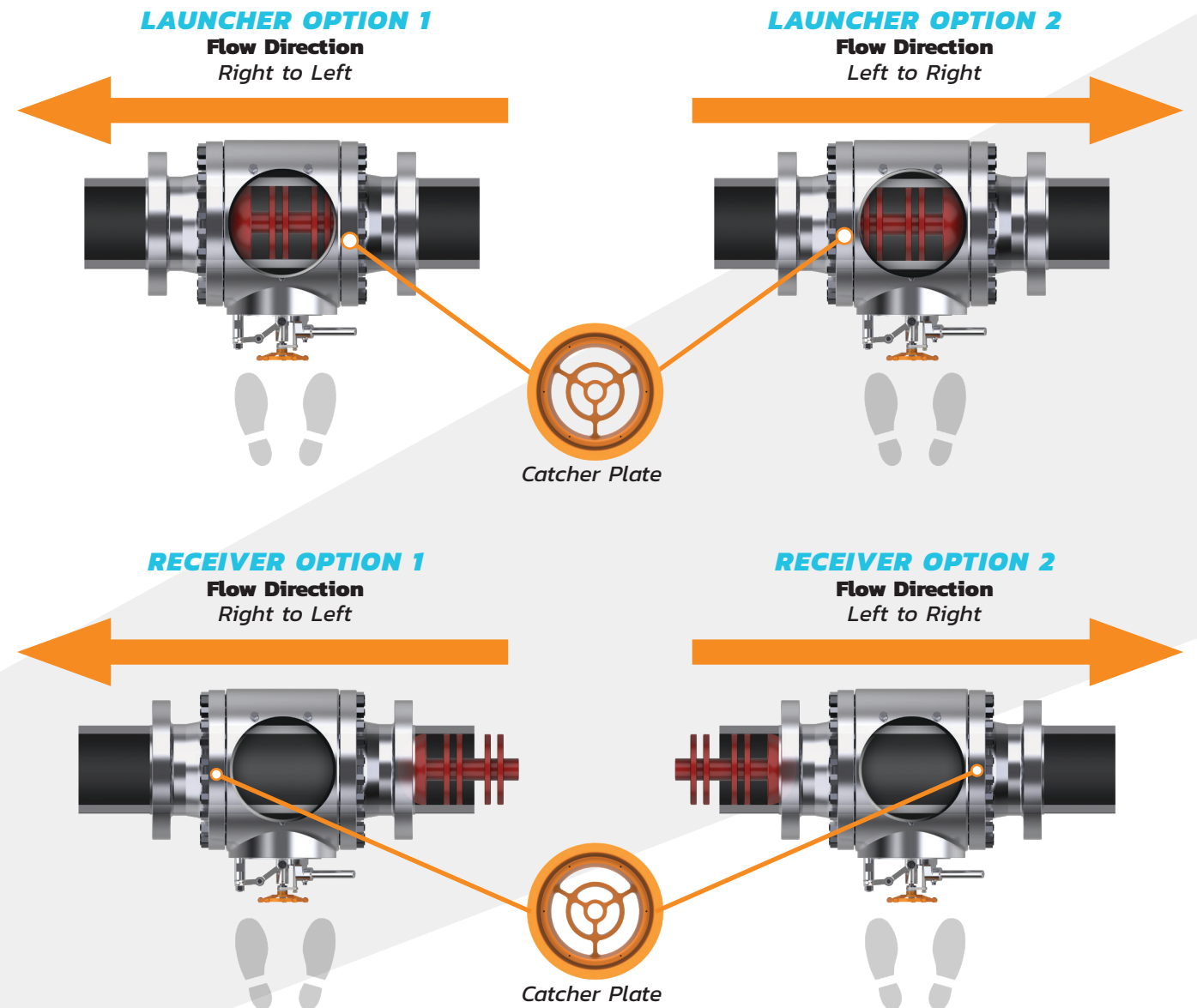
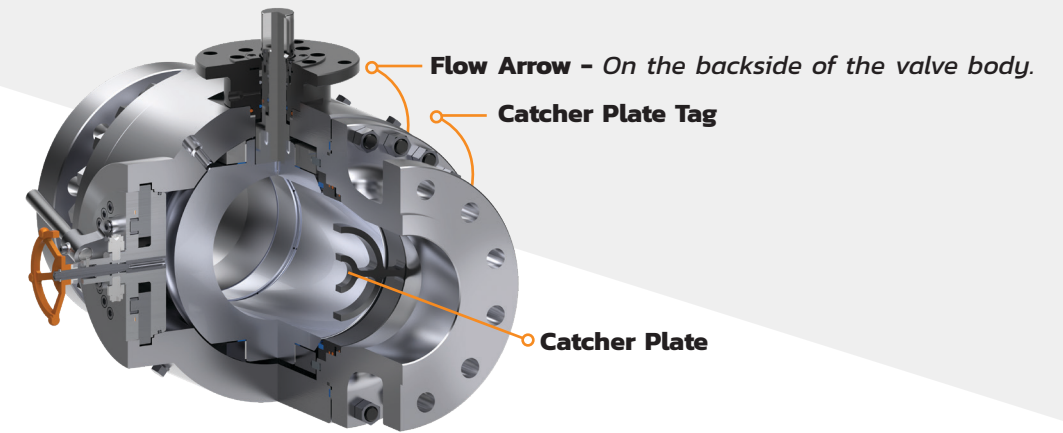

LAUNCHING

Before opening any fittings or removing the closure make sure the ball is in the closed position. The stem and/or handle can both be used to indicate the ball bore position. The valve will be marked with an X, atop the flange, to indicate the catcher / receiver position. (See the orientation sheet for details).

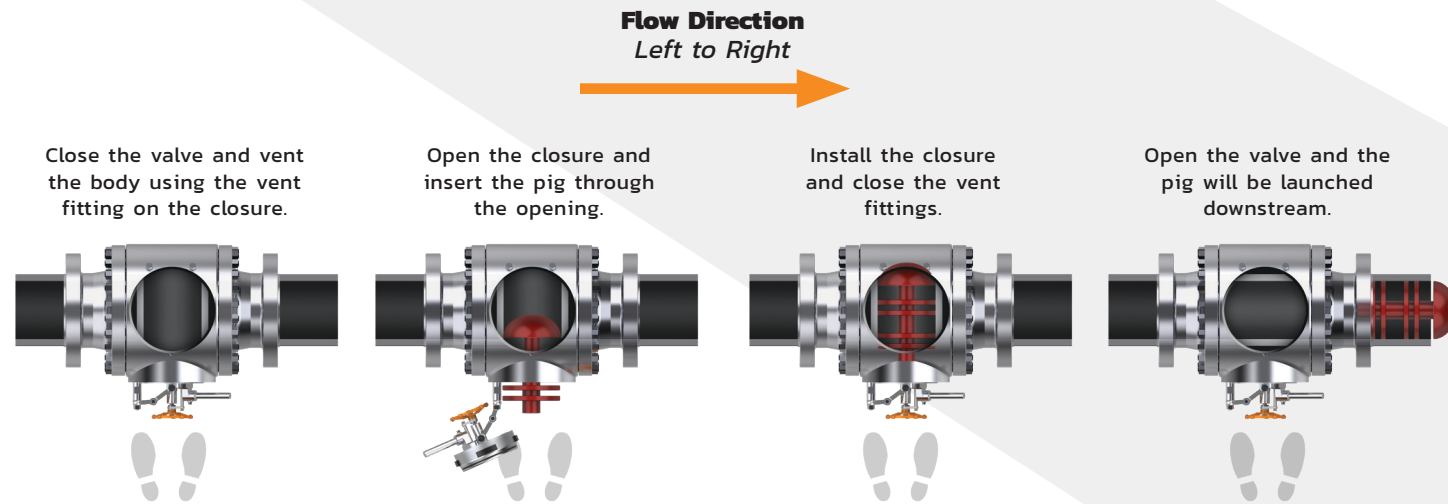

CAUTION must be used when opening any fittings or the closure. Venting gases or draining the valve may be hazardous, check and follow all local, state and federal regulations before venting. Use proper safety precautions and HSE procedures. Open all vent fittings slowly and make sure they are pointed away from your body or face.

Step 1: Close valve and vent body cavity using vent valve located on body of the valve.

Step 2: Open secondary safety vent valve located on closure door, thus venting any excess pressure, releasing the mechanical stop, and unlocking the closure door.

Step 3: Open the closure door and insert the PIG.

Step 4: Re-install the closure door and close secondary safety vent valve.

Step 5: Open the valve and PIG will be Launched.

RECEIVING

Before opening any fittings or removing the closure make sure the ball is in the closed position. The stem and/or handle can both be used to indicate the ball bore position. The valve will be marked with an X, atop the flange, to indicate the catcher / receiver position. (See the orientation sheet for details).

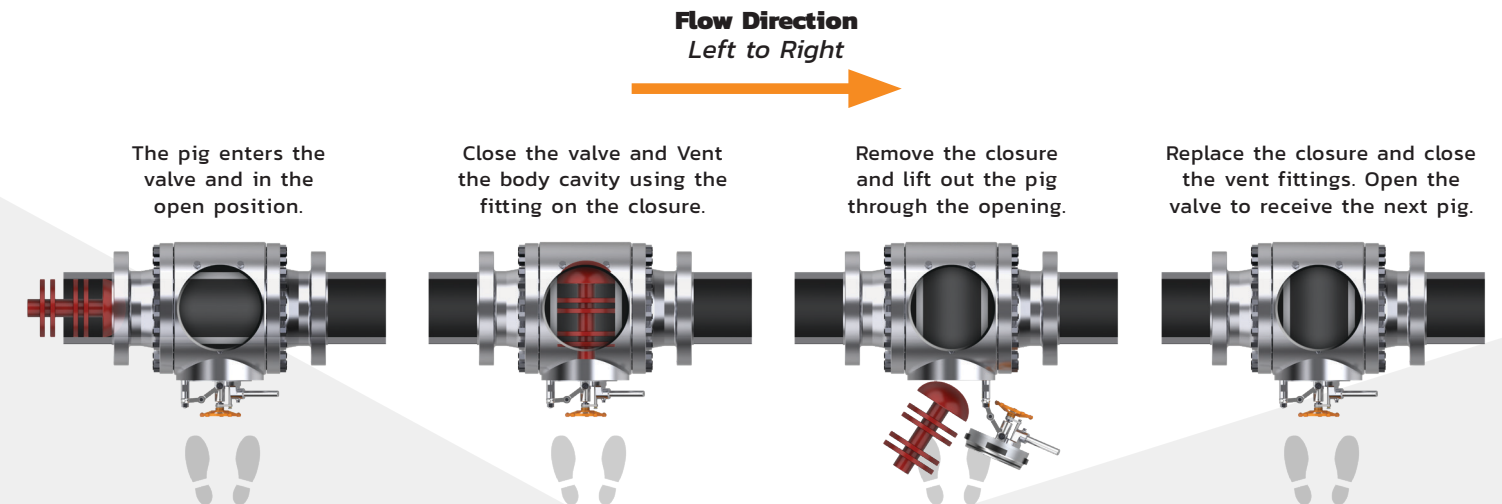

CAUTION must be used when opening any fittings or the closure. Venting gases or draining the valve may be hazardous, check and follow all local, state and federal regulations before venting. Use proper safety precautions and HSE procedures. Open all vent fittings slowly and make sure they are pointed away from your body or face.

Step 1: PIG enters the Valve

Step 2: Close valve and vent body cavity using vent valve located on body of the valve.

Step 3: Open secondary safety vent valve located on closure door, thus venting any excess pressure, releasing the mechanical stop, and unlocking the closure door.

Step 4: Open closure door and remove the PIG.

Step 5: Re-install the closure door and close secondary safety vent valve.

Step 6: Open valve to resume line flow.

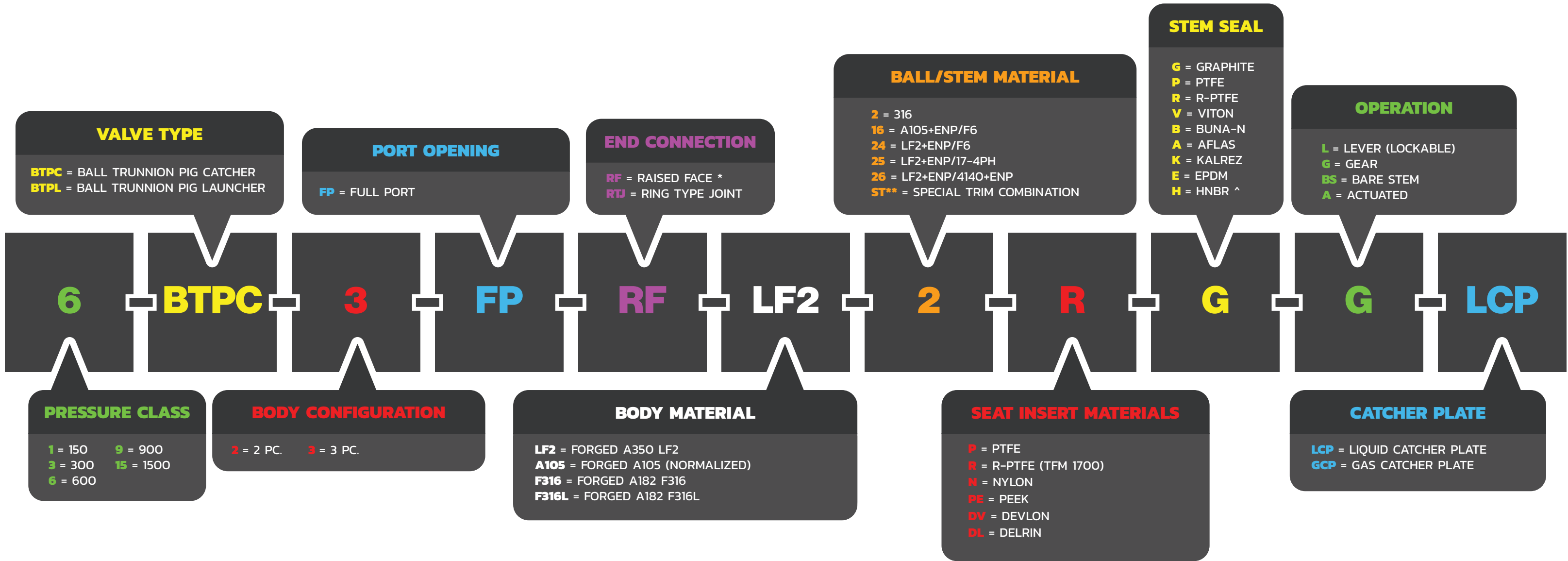

HOW TO ORDER PIG VALVES

(CDUSA Ordering Rev. 19, Mar., 2020)

This unique Valve Figure Number system is arranged to cover the basic valve design features. When ordering, please include this basic Figure Number and add any additional design requirements and features in a complete valve description. Valve designs, materials, trims and other features are not limited to those listed below.

* Customer to advise end flange design for sizes above 24" at time of order placement.

** If required Ball/Stem material is not listed use "ST" and specify desired materials in valve description.

^ Specify brand name in product description. Will be mfg standard if no brand specified.

EXAMPLE: Class 600 Pig Trunnion Ball Valve Catcher 3 Piece Body Full Port Raised Face LF2 Body 316 Trim Devlon Seats Viton O-ring Stem Seal with backup Graphite Packing Gear Operated Liquid Catcher Plate

6-BTPC-3-FP-RF-LF2-2-DV-V-G-LCP



CHAODA GROUP USA CO., LTD.
10633 West Airport Blvd., Suite 200
Stafford, TX 77477
T: (832) 939-9944
F: (832) 939-9942
www.chaodausa.com



Patton Myhre
15002 Boudreaux Rd
Tomball, TX 77377
T: (281) 256-0467
F: (281) 256-3780
www.pattonmyhre.com

